



Indoor and Outdoor Insect Killer

Instruction manual



**Model:
DF756-A**

Safety Instructions

- A service agent/qualified technician should carry out installation and any repairs if required. Do not remove any components on this product.
- Consult Local and National Standards to comply with the following:
 - Health and Safety at Work Legislation
 - Fire Precautions
 - IEE Wiring Regulations
 - Building Regulations
- Always disconnect the power supply to the appliance before cleaning.
- Install the appliance out of the reach of children.
- Never insert hands or other objects into the appliance while it is connected to the power supply.
- Install the Insect killer at least 1 metre away from food preparation areas.
- Never use near flammable objects.
- For use under covered areas, e.g. Terraces, marquees, etc.
- This product should be plugged into a suitable socket that is designed for outdoor use.
- Keep all packaging away from children.
- If the power cord is damaged, it must be replaced by an EAZYZAP agent or a recommended qualified technician in order to avoid a hazard.
- EAZYZAP recommend that this appliance should be periodically tested (at least annually) by a Competent Person. Testing should include, but not be limited to: Visual Inspection, Polarity Test, Insulation Continuity and Functional Testing.

- **Danger - High voltage!** ⚡
- The appliance emits UV radiation. Do not stare at the light.
- The appliance is not to be used in locations where flammable vapour or explosive dust is likely to exist.
- Do not use in barns, stables and similar locations.
- Children should be supervised to ensure that they do not play with the appliance.

Introduction

Please take a few moments to carefully read through this manual. Correct maintenance and operation of this machine will provide the best possible performance from your EAZYZAP product.

Pack Contents

The following is included:

- Insect Killer
- Instruction manual

EAZYZAP prides itself on quality and service, ensuring that at the time of packaging the contents are supplied fully functional and free of damage.

Should you find any damage as a result of transit, please contact your EAZYZAP dealer immediately.

Installation

Note: Ensure the mounting substrate and the fixings used can support the weight of the appliance. If in doubt seek professional advice or assistance.

1. Remove all packaging and protective film from the Insect killer.
2. For best results, locate the Insect killer in the darkest part of the room, but at least 1 metre away from food preparation areas.

Note: Close proximity to other light sources such as sky lights and windows will reduce the effectiveness of the Insect killer.

Operation



WARNING: Under no circumstances should hands be placed anywhere near the high voltage grid when the appliance is operational.

The insect killer works by luring insects on to an electrified metal grid using ultra-violet light. It uses no chemicals and is pollution free. To use the Insect killer:

1. Connect the appliance to mains power.
2. The light will come on and the grid will become electrically charged.

Cleaning, Care & Maintenance



Always disconnect the appliance from the power supply before cleaning.

- Clean the collection tray regularly with warm soapy water.
- DO NOT immerse the appliance in water. Wipe the safety guard and external casing with a damp cloth.
- Change the bulbs every 9 months.

Changing the Bulb

WARNING: Always disconnect the appliance from the power supply before changing the bulb.

1. Unscrew the collection tray [Fig. 1].
2. Lay the appliance on the side.
3. Unscrew the two screws holding the bottom plate [Fig. 2].
4. Hold the ends of the bulb and just pull to remove it from its socket.
5. Replace with a new bulb.
6. Re-locate the bottom plate and screws.
7. Screw the collection tray back into place.

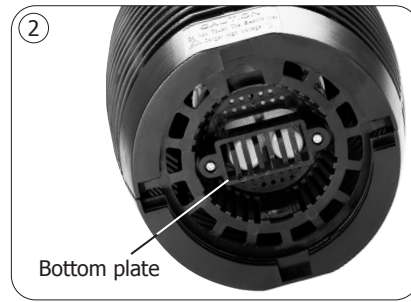

Troubleshooting

A qualified technician must carry out repairs if required.

Fault	Probable Cause	Solution
The appliance is not working	The unit is not switched on	Check the unit is plugged in correctly and switched on
	Plug or lead is damaged	Replace plug or lead
	Mains power supply fault	Check mains power supply
	Tube has expired	Refer to the Section 'Changing the Bulb'
	Tube is faulty or has not been fitted correctly	

Technical Specifications

Note: Due to our continuing program of research and development, the specifications herein may be subject to change without notice.

Model	Voltage	Power	Dimensions h x w x d (mm)	Weight	Lamp type
DF756-A	220-240V~ 50-60Hz	19W	315 x 170 x 165	1.02kg	PL 18W

Electrical Wiring

The plug is to be connected to a suitable mains socket.

This appliance is wired as follows:

- Live wire (coloured brown) to terminal marked L
- Neutral wire (coloured blue) to terminal marked N

If in doubt consult a qualified electrician.

Electrical isolation points must be kept clear of any obstructions. In the event of any emergency disconnection being required they must be readily accessible.

Compliance

The product must not be disposed of as household waste. To help prevent possible harm to human health and/or the environment, the product must be disposed of in an approved and environmentally safe recycling process. For further information on how to dispose of this product correctly, contact the product supplier, or the local authority responsible for waste disposal in your area.

EAZYZAP parts have undergone strict product testing in order to comply with regulatory standards and specifications set by international, independent, and federal authorities.

EAZYZAP products have been approved to carry the following symbol:



All rights reserved. No part of these instructions may be produced or transmitted in any form or by any means, electronic, mechanical, photocopying, recording or otherwise, without the prior written permission of EAZYZAP. Every effort is made to ensure all details are correct at the time of going to press, however, EAZYZAP reserve the right to change specifications without notice.

DECLARATION OF CONFORMITY

- Conformiteitsverklaring • Déclaration de conformité • Konformitätserklärung • Dichiarazione di conformità •
• Declaración de conformidad

Equipment Type • Uitrustingstype • Type d'équipement • Gerätyp • Tipo di apparecchiatura • Tipo de equipo		Model • Modèle • Modell • Modello • Modelo
Outside Lantern Insect Killer 80M ²		DF756 (-E & -A)
Application of Territory Legislation & Council Directives(s) Toepassing van Europese Richtlijn(en) • Application de la/des directive(s) du Conseil • Anwendbare EU-Richtlinie(n) • Applicazione delle Direttive • Aplicación de la(s) directiva(s) del consejo	<p>Low Voltage Directive (LVD) - 2014/35/EU Electrical Equipment (Safety) Regulations 2016 (BS) EN 60335-1:2012 +A11:2014 +A13:2017 +A1:2019 +A14:2019 +A2:2019 (BS) EN 60335-2-59:2003 +A1:2006 +A2:2009 +A11:2019 (BS) EN 62233:2008</p> <p>Electro-Magnetic Compatibility (EMC) Directive 2014/30/EU - recast of 2004/108/EC Electromagnetic Compatibility Regulations 2016 (S.I. 2016/1091) (BS) EN IEC 55014-1:2021 (BS) EN IEC 55014-2:2021 (BS) EN IEC 61000-3-2:2019 +A1:2021 (BS) EN 61000-3-3: 2013 +A1:2019</p> <p>Restriction of Hazardous Substances Directive (RoHS) 2015/863 amending Annex II to Directive 2011/65/EU Restriction of the Use of Certain Hazardous Substances in Electrical and Electronic Equipment Regulations 2012 (S.I. 2012/3032)</p>	<p>Electrical Safety AS/NZS 60335.1:2020 +A1:2021 AS/NZS 60335.2.59:2005 +A1:2005 +A2:2006 +A3:2010</p> <p>Electromagnetic Compatibility EN IEC 55014-1:2021 EN IEC 55014-2:2021 EN IEC 61000-3-2:2019 +A1:2021 EN 61000-3-3: 2013 +A1:2019</p>
Producer Name • Naam fabrikant • Nom du producteur • Name des Herstellers • Nome del produttore • Nombre del fabricante		Eazyzap

I, the undersigned, hereby declare that the equipment specified above conforms to the above Territory Legislation, Directive(s) and Standard(s).

Ik, de ondergetekende, verklaar hierbij dat de hierboven gespecificeerde uitrusting goedgekeurd is volgens de bovenstaande Richtlijn(en) en Standaard(en).

Je soussigné, confirme la conformité de l'équipement cité dans la présente à la / aux Directive(s) et Norme(s) ci-dessus
Ich, der/die Unterzeichnende, erkläre hiermit, dass das oben angegebene Gerät der/den oben angeführten Richtlinie(n) und Norm(en) entspricht.

Il sottoscritto dichiara che l'apparecchiatura di sopra specificata è conforme alle Direttive e agli Standard sopra riportati.

El abajo firmante declara por la presente que el equipo arriba especificado está en conformidad con la(s) directiva(s) y estándar(es) arriba mencionadas.

Date • Data • Date • Datum •
Data • Fecha

Signature • Handtekening •
Signature • Unterschrift Firma •
Firma

Full Name • Volledige naam •
Nom et prénom • Vollständiger
Name • Nome completo •
Nombre completo

Position • Functie • Fonction •
Position • Qualifica • Posición

Producer Address • Adres
fabrikant • Adresse du
producteur • Anschrift des
Herstellers • Indirizzo del
produttore • Dirección del
fabricante

14 th September 2023		
DocuSigned by: <i>Ashley Hooper</i> B39382C9FD9C478...	DocuSigned by: <i>Eoghan Donnellan</i> D352874F7FAB460...	DocuSigned by: <i>Brendan Denmeade</i> 386FAD00DFE8483...
Ashley Hooper	Eoghan Donnellan	Brendan Denmeade
Technical & Quality Manager	Commercial Manager/ Importer	Commercial Manager/ Responsible Supplier
Fourth Way, Avonmouth, Bristol, BS11 8TB United Kingdom	Unit 9003, Blarney Business Park, Blarney, Co. Cork Ireland	15 Badgally Road, Campbelltown NSW 2560





DF756-A_A5_v1_2023/09/19